

Withings Body

BMI - Wi-Fi scale

Installation and operating instructions



Table of contents

Minimum requirements	5
Internet access.....	5
Smartphone or device	5
OS version.....	5
Health Mate App version	5
Withings Body description	6
Overview.....	6
Box contents.....	6
Product description	7
Scale screens description.....	7
Setting up the Withings Body	8
Installing the Health Mate app.....	8
Installing your Withings Body.....	8
Customizing your Withings Body	20
Changing the configuration of your Withings Body.....	20
Changing the settings of your Withings Body	23
Using your Withings Body	28
Tracking your weight.....	28
Checking the weather	32
Using Baby mode.....	33
Using Pregnancy Mode	35
Linking your account to MyFitnessPal	37
Syncing your data	38
Dissociating your Withings Body	39
Performing a factory reset of your Withings Body	41
Cleaning and maintenance	42
Cleaning your Withings Body	42
Changing the batteries.....	42
Installing the carpet feet.....	43

Updating your Withings Body	43
Technology description	46
Weight	46
Body Mass Index.....	46
User guide copyright.....	47
Legal notice.....	47
Personal data.....	47
Safety instructions.....	48
Use and storage	48
Location	48
Service and maintenance	48
Specifications	49
Document release overview	51
Warranty.....	52
Regulatory statements	53

Important notice

By using your Withings Body you expressly agree to the Withings Services Terms and Conditions available on our [website](#).

Minimum requirements

Internet access

Access to the Internet is required to:

- Download the Health Mate app,
- Set up your Withings Body,
- Upgrade the firmware.

For more details, refer to [“Specifications” on page 49](#).

We recommend using the app on a device connected to the Internet to enjoy all features.

Smartphone or device

An iOS device or Android device (with operational Bluetooth and Wi-Fi or 3G/4G) is required to:

- Set up your Withings Body,
- Retrieve data from your Withings Body,
- Access specific functions of your Withings Body.

Bluetooth Low Energy (BLE) compatibility is recommended to install your Withings Body.

For more details, refer to [“Specifications” on page 49](#).

OS version

You need iOS 8 or higher or Android 5.0 or higher to install and run the Health Mate App.

Health Mate App version

We recommend that you use the latest available version of the Health Mate app to have all the latest features available.

Withings Body description

Overview

The Withings Body allows you to easily track your weight and monitor your progress. Not only does it let you know how much you weigh, it also calculates your Body Mass Index (BMI) to give you a better idea of where you stand as far as weight-related risks are concerned.

Of course that's not all your Withings Body does. If you activate the Weather screen, you also get your daily weather report everytime you weigh in.

Because the Withings Body is a connected scale, its true potential is achieved when you use it along with the Health Mate app. Beside allowing you to install your scale, the Health Mate app allows you to customize its display, to set a weight goal, and to check the entire history of your weight data.

Thanks to its in-app activity tracking feature and the numerous partner apps you can connect it to, the Health Mate app helps you reach your weight goal faster by helping you track your activity and check your calorie balance.

Box contents



(1) Withings Body

(2) Carpet feet

(3) Batteries (inserted)

Product description

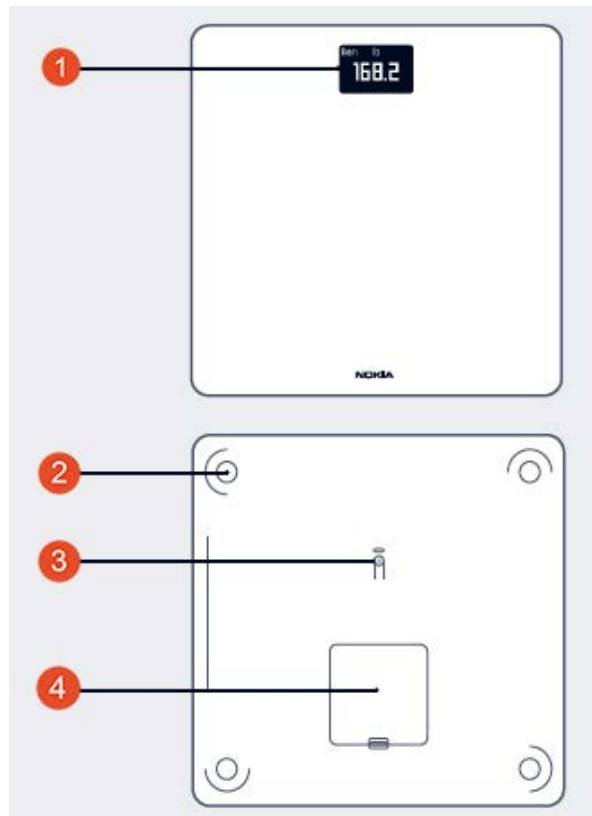

(1) Screen

(2) Feet

(3) Unit and pairing
button

(4) Battery cover

Scale screens description

You can select a number of screens to be displayed on your Withings Body:

- Weight: Displays your weight. This screen cannot be disabled.
- BMI: Displays your Body Mass Index.
- Weather¹: Displays the weather for the day.
- Steps^{1, 2}: Displays the number of steps you did the previous day.

You can disable or change the order of these screens as you like after you install your Withings Body. Otherwise, they will appear in the default order. Refer to [“Changing the screen order” on page 23](#) for more information.

¹ This screen can only be used if you set up your Withings Body in Wi-Fi.

² You either need to own a Withings tracker, or to use the in-app tracking of the Health Mate app to display your number of steps on this screen. If you don't have a Withings tracker, tap on Activity in your Dashboard in the Health Mate app and tap **Activate now**. Your mobile device will then start tracking your steps.

Setting up the Withings Body

Installing the Health Mate app

If the Health Mate app is not already installed on your device, perform the following steps:

1. Go to go.withings.com in your device's web browser.
2. Tap **Download** on the App Store or on the Play Store.
3. Tap **Get**.
The installation process starts.

Installing your Withings Body

Overview

Installing your Withings Body in Wi-Fi gives you access to all the features and screens available. Installing your Withings Body in Bluetooth limits the features and screens available. For example, you can't use the Weather screen and the Steps screen, as they require access to the Internet.

You can change the configuration of your Withings Body anytime you want. Refer to "[Changing the configuration of your Withings Body](#)" on page 20 for more information.

Note that once you've installed your Withings Body on your account, all the users of the account can use it. You are also free to install it on various accounts. There is, however, a limit of eight users per scale at the moment.

I'm new to Health Mate

1. Pull the tab out of the battery compartment if it's the first time you install your Withings Body.

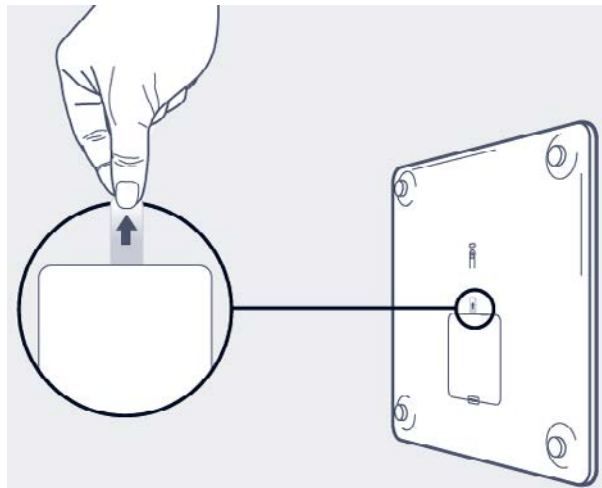

2. Open the Health Mate app.
3. Tap **Get Started**.

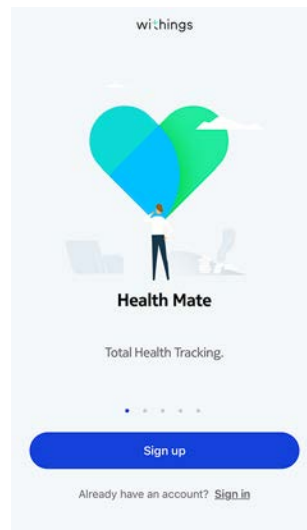

4. Tap **Scales**.

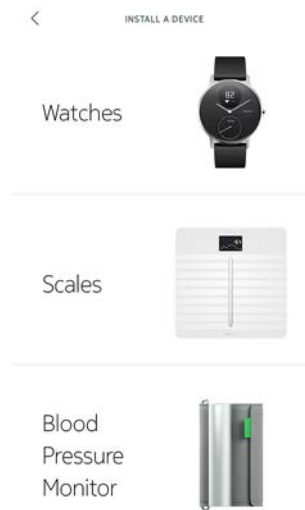

5. Tap **Withings Body**.

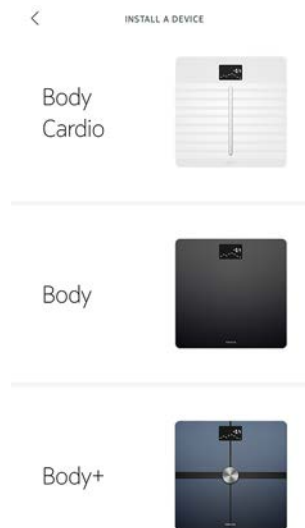

6. Tap **Install**.



7. Press the button at the back of the scale for three seconds and tap **Next**.

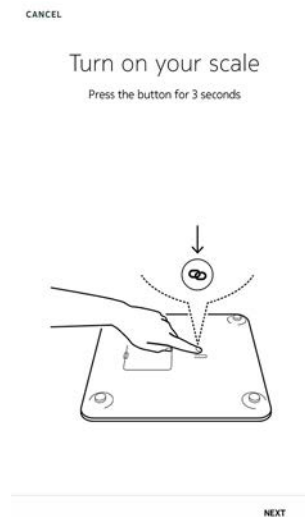

8. Tap **Next**.



9. Tap **Pair** (iOS only).



10. Tap **Pair**. (iOS only).

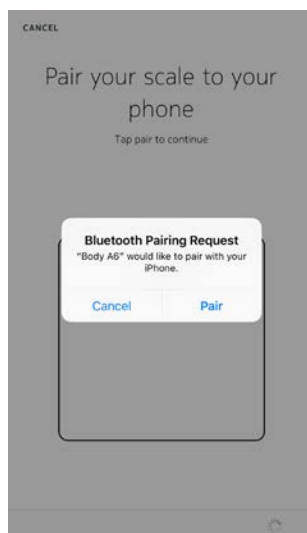

11. Tap **Next**.



12. Enter your email and password. Tap **Create**.

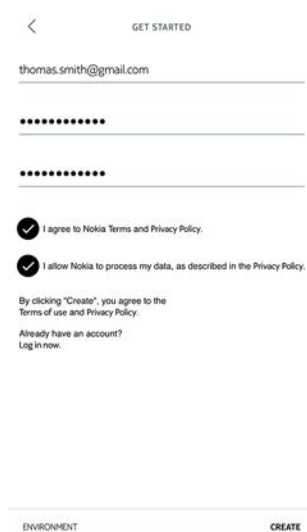

13. Enter your first name, surname and birthday.

14. Select your gender and enter your height and weight. Tap **Next**.

15. Tap **Change the avatar** if you want to change it.
16. Tap **Next**.
You have the possibility to add a family member if you want to.
17. To install your scale in Wi-Fi, perform the following steps:
 - a. Tap **Quick setup** to use the same Wi-Fi network as your mobile device or **Setup another network** to use another one.



- b. Tap **Allow**.

You will need to update the Wi-Fi configuration if you change the network name or password. Refer to [“Changing the configuration of your Withings Body” on page 20](#) for more information.

18. To install your scale in Bluetooth, tap **I don't have a Wi-Fi Network**.

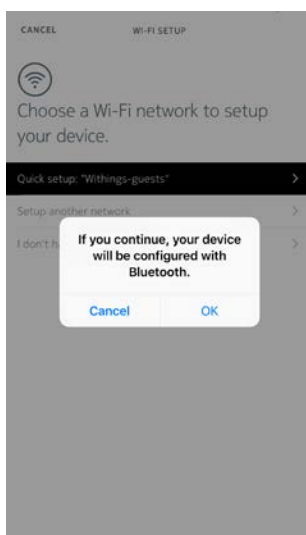

19. Tap **OK**.
20. Tap **Close**.
The Health Mate now prompts you to select your target weight. Tap **Cancel** if you don't want to set a weight goal. You can set one later on if you change your mind. Refer to [“Changing your weight goal” on page 29](#) for more information.

The Withings Body is updating and restarting.

21. Tap **Done**.



I already have a Health Mate account

1. Pull the tab out of the battery compartment if it's the first time you install your Withings Body.

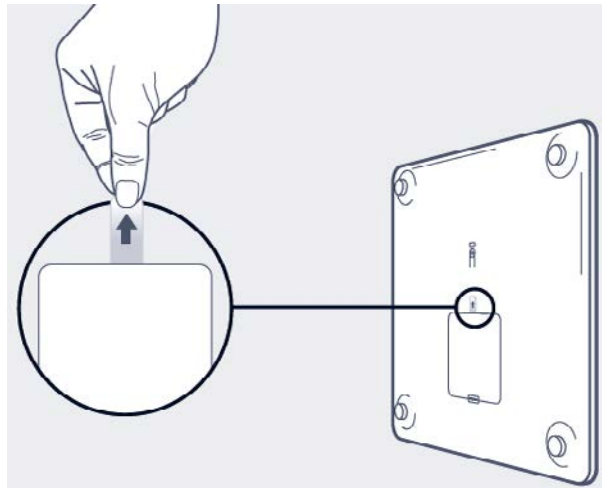

2. Open the Health Mate app.
3. Go to **Devices**.
4. Tap **+**.

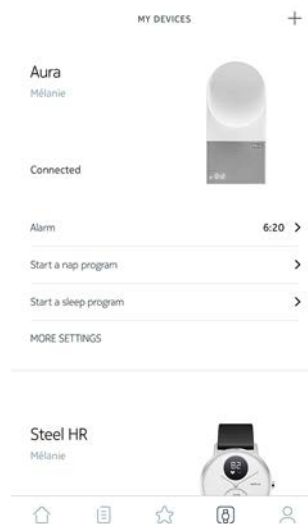

5. Tap **Scales**.

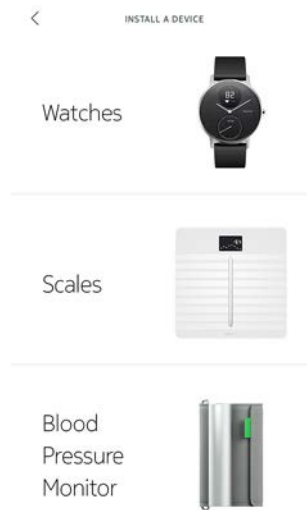

6. Tap **Withings Body**.

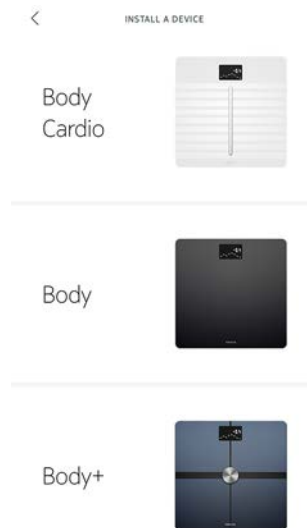

7. Tap **Install**.



8. Press the button at the back of the scale for three seconds and tap **Next**.



9. Tap **Next**.



10. Tap **Pair** (iOS only).



11. Tap **Pair** (iOS only).

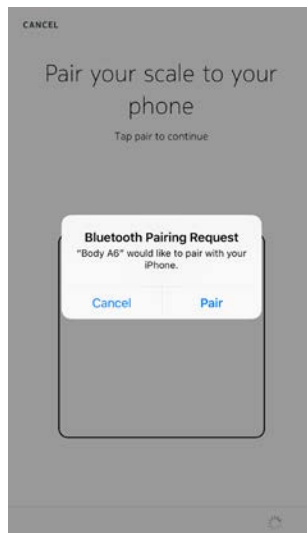

12. Tap **Next**.



13. To install your scale in Wi-Fi, perform the following steps:
a. Tap **Quick setup** to use the same Wi-Fi network as your mobile device or **Setup another network** to use another one.



b. Tap **Allow**.

You will need to update the Wi-Fi configuration if you change the network name or password. Refer to [“Changing the configuration of your Withings Body” on page 20](#) for more information.

14. To install your scale in Bluetooth, tap **I don't have a Wi-Fi Network**.

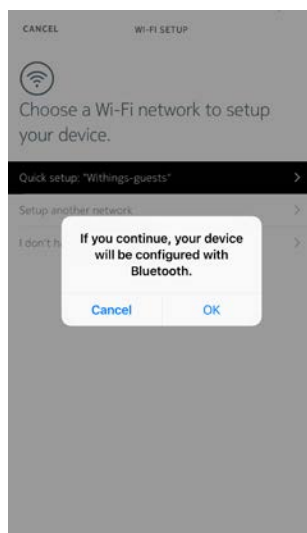

15. Tap **OK**.

16. Tap **Close**.

The Withings Body is updating and restarting.

17. Tap **Done**.



The Health Mate now prompts you to select your target weight.

Selecting your weight goal

To select your weight goal, perform the following steps:

1. Tap and slide up or down to select your target weight.

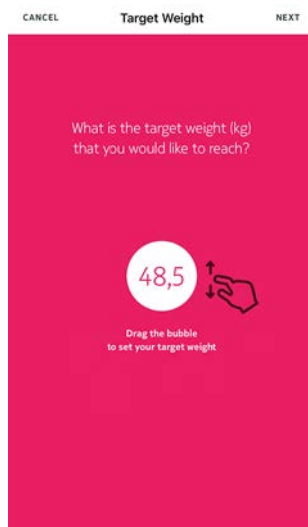

2. Tap **Next**.
3. Tap and slide up or down to select the pace at which you want to achieve your weight goal.

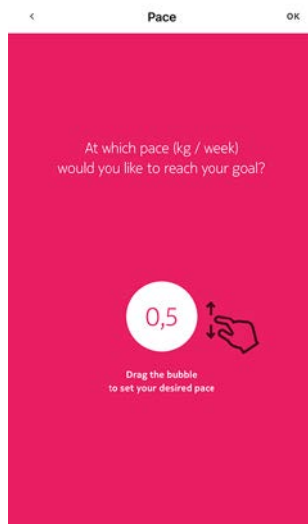

4. Tap **OK**.

Customizing your Withings Body

Changing the configuration of your Withings Body

You may need to change the configuration of your Withings Body:

- If you want to use a different Wi-Fi network,
- If you want to switch to a Wi-Fi configuration,
- If you want to switch to a Bluetooth configuration.

To change your configuration, perform the following steps:

1. Open the Health Mate app.
2. Go to **Devices**.
3. Tap **Withings Body**.

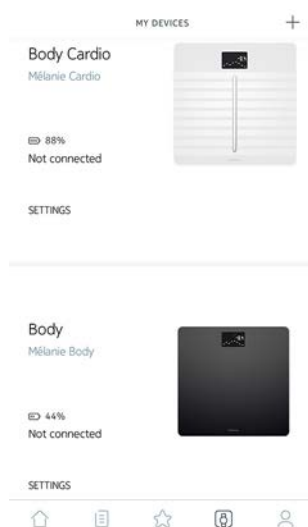

4. Tap **Update Wi-Fi Configuration**.

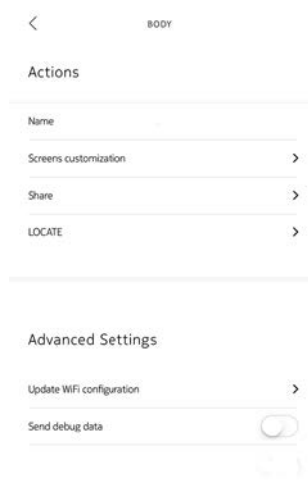

5. Press the button at the back of the scale and tap **Next**.

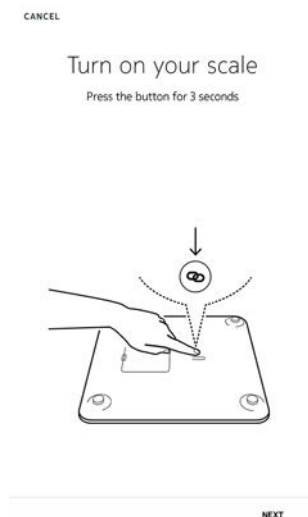

6. Tap **Next**.



7. To install your scale in Wi-Fi, perform the following steps:
a. Tap **Quick setup** to use the same Wi-Fi network as your mobile device or **Setup another network** to use another one.



- b. Tap **Allow**.
8. To install your scale in Bluetooth, tap **I don't have a Wi-Fi Network**.

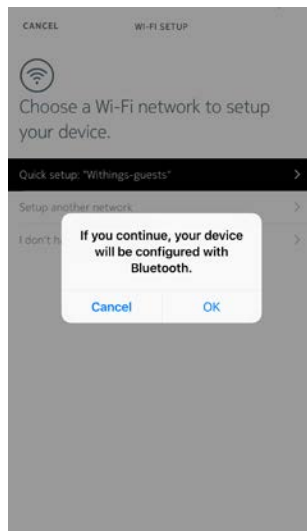

9. Tap **OK**.
10. Tap **Close**.

Changing the settings of your Withings Body

Changing the weight unit

You have the choice between three weight units: kilogram (kg), stone (stlb) and pound (lb). To change the units on your Withings Body, perform the following steps:

1. Press and hold the button at the back of your Withings Body for a few second.
2. Press the button again to change the unit.
3. Check the screen of your scale to see the unit change. The unit change is confirmed a few seconds after you stop pressing the button.

Changing the screen order

You can change the order of the screens of your Withings Body, for example if you want to display the Weather or BMI screens first. To do so, perform the following steps:

1. Open the Health Mate app.
2. Go to **Devices**.
3. Tap **Withings Body**.

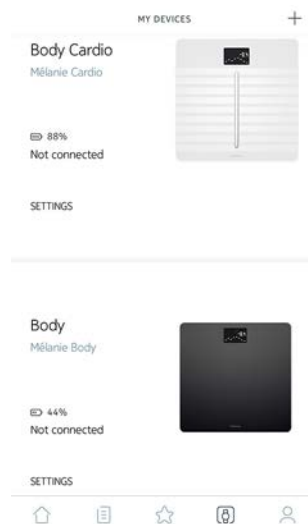

4. Tap **Screens customization**.

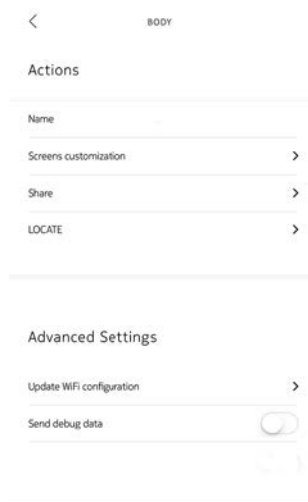

5. Tap the user profile for which you want to change the screen order.

6. Select the screens you want to display:

- Tap the black circles on the left to hide a screen.
- Tap the empty circles on the left to display a screen.



7. Tap and hold the icon on the right to drag a screen up or down.



8. Tap the back button to confirm.

9. Weigh yourself once to synchronize your Withings Body with your app and finalize the change.

The change will be effective for your next weigh-in.

Changing the location of your scale

The location of your scale is used to provide you with the correct weather forecast if you have activated the Weather screen. It is based on your IP address but it is not always accurate. If the preset location of your scale happens to be incorrect, you are free to change it anytime you want. To do so, perform the following steps:

1. Open the Health Mate app.
2. Go to **Devices**.
3. Tap **Withings Body**.

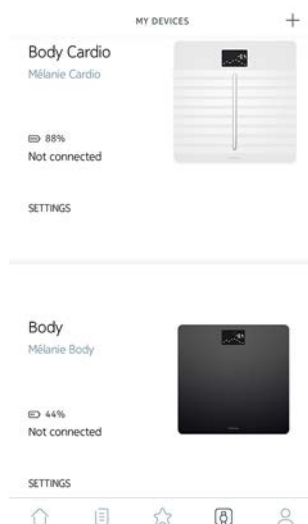

4. Tap **Locate**.

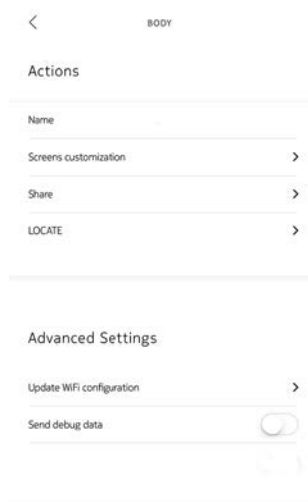

5. Tap **Allow**.

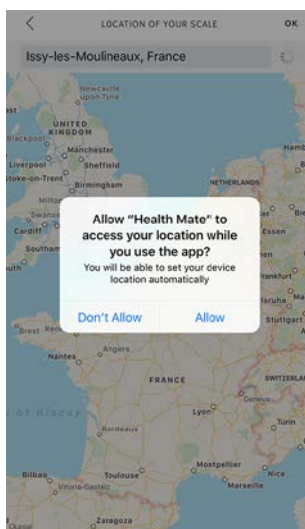

6. Tap **OK**.



Using your Withings Body

Tracking your weight

Overview

The Withings Body allows you to track your weight and Body Mass Index (BMI). It also lets you see how your weight trend changes over time.

Make sure you follow the recommendations below to get accurate and representative weight measurements:

- Make sure you always weigh yourself around the same time to improve the consistency of your measurements.
- Wait five seconds before weighing yourself if you have just moved your scale.
- If your scale is on a carpet, make sure you're using the carpet feet. Refer to [“Installing the carpet feet” on page 43](#) for more information.

Weighing yourself

Thanks to the Position Control™ technology, getting an accurate weight measurement has never been easier. If your weight is not properly distributed on your Withings Body, arrows are displayed on the scale to indicate in which direction you should lean to stabilize your weight.

If several users have a similar weight, the following screen can be displayed:



Simply lean left or right to select the correct name.

Retrieving your weight data

As soon as you weigh yourself, your weight is displayed on the display of your scale. If you've activated the Weight Trend screen, you'll also see a graph showing your eight last measurements as well as the delta between the latest measurement and the previous one.

To see detailed graphs about your weight and see your full history, you have to check your data on the Health Mate app.

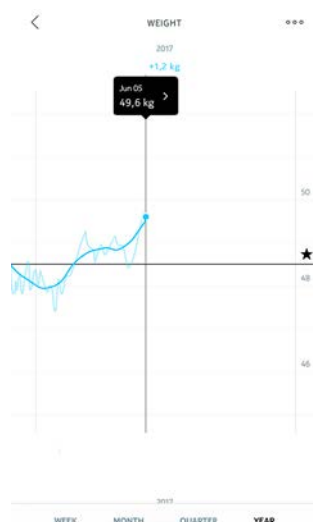

You can access your graphs:

- By tapping the Weight widget on your Dashboard.
- By tapping any weight measurement item in your Timeline.

Once you're viewing the weight graph, you can alternate between the tabs to view your weight graph and your BMI graph.

Changing your weight goal

To change your weight goal, perform the following steps:

1. Open the Health Mate app.
2. Select the **Dashboard** view.



3. Tap **Weight**.
4. Tap on three dots in the upper right hand corner
5. Tap **Change my weight goal**

6. Tap and slide up or down to select your target weight.



7. Tap **Next**.

8. Tap and slide up or down to select the pace at which you want to achieve your weight goal.

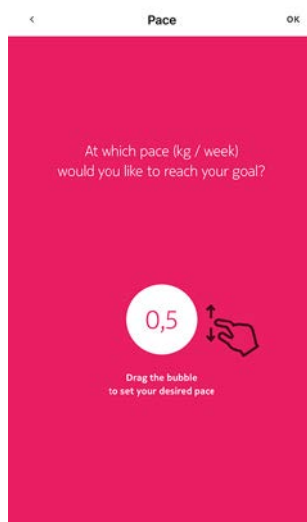

9. Tap **OK**.

Retrieving unknown measurements

If your Withings Body doesn't recognize you when you weigh in, your weight measurements will be listed as unknown measurements. To assign them to a user, perform the following steps:

1. Open the Health Mate app.
2. Go to **Devices**.

3. Tap **Unknown measurements**.

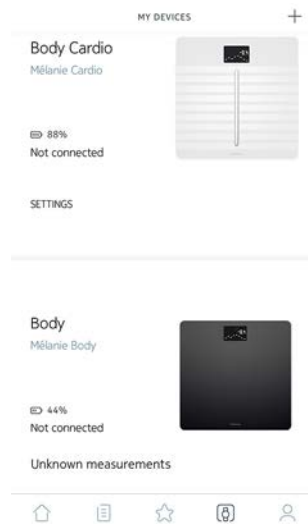

4. Select the **Unknown measurement**.



5. Tap the user you want to assign the measurement to.

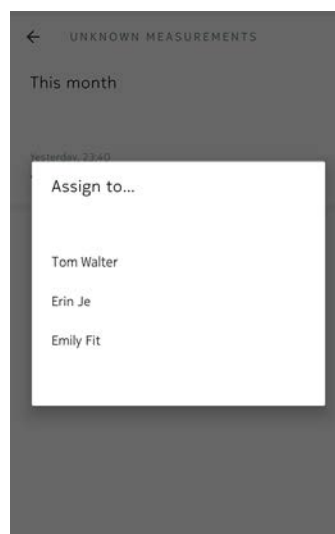

Checking the weather

Overview

You can check the local weather forecast for the day directly on your Withings Body if the following conditions are met:

- Your Withings Body is set up in Wi-Fi. Refer to [“Changing the configuration of your Withings Body” on page 20](#) for more information on how to switch to a Wi-Fi configuration.
- The Weather screen is enabled. Refer to [“Changing the screen order” on page 23](#) for more information.

Retrieving weather information

All you have to do to retrieve weather information on your Withings Body is to step on the scale and wait for the Weather screen to be displayed.

The Weather screen provides you with information about the average weather and temperature for the morning (between 6:00 AM and 12:00 PM) and for the afternoon (between 12:00 PM and 9:00 PM).



If you weigh yourself in the morning, the data of the day is displayed. If you weigh after 7:00 PM, the data of the next day is displayed.

Using Baby mode

Baby mode allows you to find out the weight of your baby by weighing yourself on the scale while holding your baby. To use this mode, you must create a profile for your baby in the Health Mate app. Then enter the height and weight of your baby and weigh yourself while holding your baby in your arms. The weight of your baby will be automatically detected by the scale.

Important: your baby must weigh between 7 and 33 lbs (3 and 15 kg) to be detected by the scale. As Baby mode is enabled by default on the Withings Body, you do not need to enable it in the Health Mate app.

Follow the steps below to use Baby mode:

1. Create a profile for your baby in the Health Mate app.
2. Enter the height and weight of your baby.
3. Weigh yourself on your own.

Your weight will be displayed on the screen of the Withings Body.

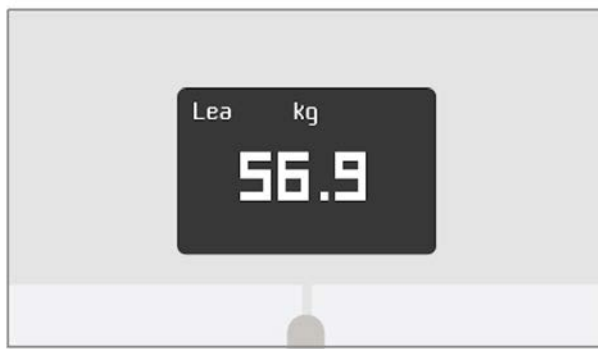

4. Weigh yourself with your baby (within 5 minutes of first weighing yourself). The scale will display your weight plus your baby's weight, followed by the weight of your baby on its own.

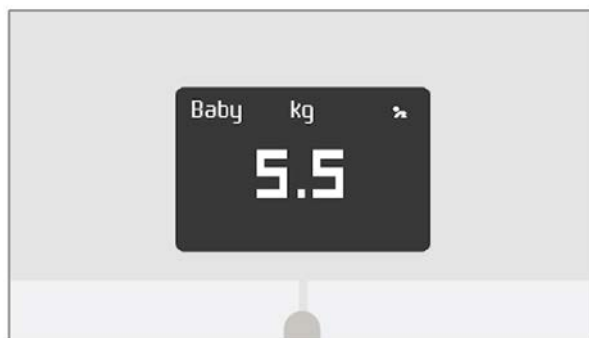
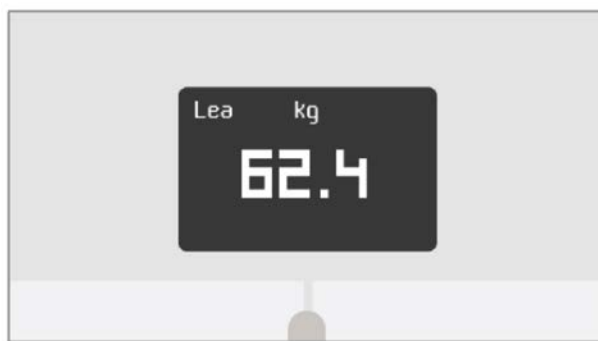

For best results, we recommend you to weigh yourself when your baby is calm.

Note: you can use Baby mode for several members of your family. For example, you may wish to add a profile for your baby to your account or create a separate account for your baby. Please note that you can add up to 8 users to your Withings account.

Using Pregnancy Mode

Pregnancy Mode provides an enriched Health Mate experience for pregnant women, offering advice, tips, and easy weight tracking throughout pregnancy.

Pregnant women will receive the following information on a weekly basis in their Health Mate Timeline:

- an overview of the week with the current stage of pregnancy and cumulative weight gain, along with how it compares with your personalized recommendations
- health-related and obstetrician-reviewed information relevant to the current week of pregnancy

Activating Pregnancy Mode

Pregnancy Mode can be activated by any woman at any time during pregnancy. To do so, perform the following steps:

1. Open the Health Mate app.
2. Go to **Wellness Programs**.
3. Tap **Learn more**.



4. Tap **Join**.



Pregnancy Tracker

Every pregnancy journey can use a reliable guide. Get quality information and weekly weight insights to help you stay on track and healthy.

**ABOUT THE PROGRAM

Big changes are underway! The Baby on Board program offers well-timed advice, tips, and easy weight tracking throughout your entire pregnancy journey. Each week you'll get obstetrician-reviewed

FAMILY
**44 WEEKS

JOIN

Linking your account to MyFitnessPal

Overview

When you monitor your weight, it can also be useful to monitor your calorie intake with apps such as MyFitnessPal to help you reach your weight goal.

Once you link both accounts, your Withings account will be able to retrieve your daily calorie intake from MyFitnessPal. You can then check the MyFitnessPal widget from your Dashboard to see your calorie balance.

MyFitnessPal can also retrieve information from your Withings account: your weight and your calorie outtake.

Your calorie outtake is based on any activity data coming from a Withings activity tracker or the in-app tracking feature of the Health Mate app. Note that tracking your activity can be a great way to help you achieve your weight goal.

Connecting to MyFitnessPal

To connect your Withings account to your MyFitnessPal account, perform the following steps:

1. Open the Health Mate app.
2. Tap **Profile**.
3. Tap **MyFitnessPal**.



4. Tap **Open**.
5. Log in to your MyFitnessPal account.

You can unlink your MyFitnessPal account and your Withings account anytime you want from your Profile.

Syncing your data

Data from your Withings Body is automatically synced, without any action required on your part. Your weight data is synced with the Health Mate app within a few minutes after you weigh in.

- 14 hours after your last weigh-in and then every 14 hours (default behavior)
- Once a night (if the Steps screen is activated)

If you've set up your Withings Body in Bluetooth, we advise that you weigh in regularly.

Dissociating your Withings Body



All data that wasn't synced before dissociating your Withings Body will be lost permanently.

Dissociating your Withings Body allows you to remove it from your account.



Dissociating your Withings Body will not remove any of the data that was synced from the Health Mate app.

To dissociate your Withings Body, perform the following steps:

1. Open the Health Mate app.
2. Go to **Devices**.
3. Tap **Withings Body**.

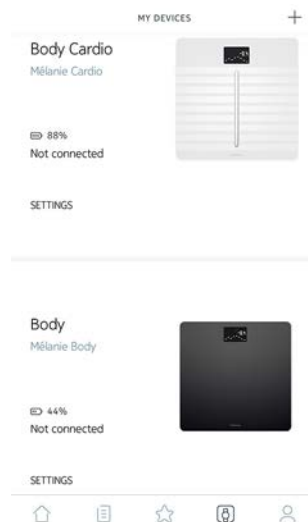

4. Tap **Dissociate this product**.



5. Tap **Remove from my account**.

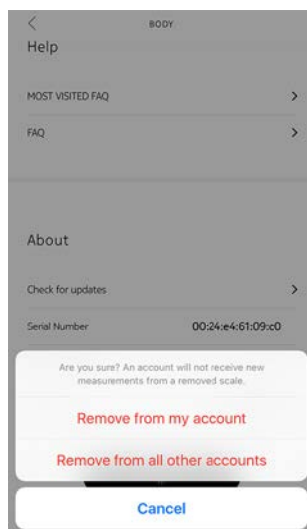

6. Perform a factory reset of your Withings Body. Refer to [“Performing a factory reset of your Withings Body”](#) on page 41 for more information.

Performing a factory reset of your Withings Body



All data that wasn't synced before factory resetting your Withings Body will be lost permanently.

Factory resetting your Withings Body allows you to delete the data stored on it. Factory resetting completes the dissociation process.



Factory resetting your Withings Body will not remove any of the data from the Health Mate app.

1. Go to the Bluetooth settings of your device and “forget” your Withings Body from the list of Bluetooth devices.
2. Remove one of the batteries for ten seconds.
3. Put the battery back.
4. When “Hello” appears on the display of your scale, press and hold the unit button at the back of the scale for 20 seconds until “Factory” appears.

At this time, you can start the installation process for the Withings Body. Refer to [“Setting up the Withings Body” on page 8](#) for more information.

Cleaning and maintenance

Cleaning your Withings Body

You can clean your Withings Body using a cloth dampened with water. If water is not enough to clean it, you can also use crystal vinegar.



Do not, under any circumstance, use any solvent to clean your Withings Body.

Changing the batteries

Your Withings Body uses 4 standard LR3 batteries and has a battery life of approximately 2 years. To check the battery level of your Withings Body, perform the following steps:

1. Open the Health Mate app.
2. Go to **Devices**.
3. Check the battery level displayed on the left.

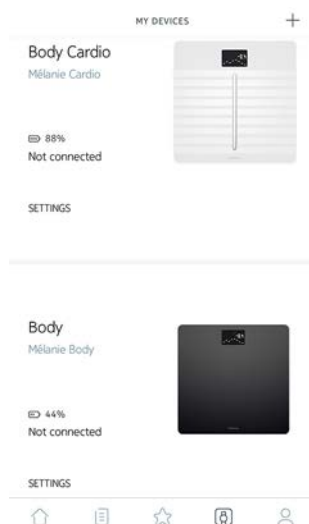

If the battery level is below 20% and you're having syncing issues, we advise that you change the batteries.

Installing the carpet feet

If you are using your Withings Body on a carpet, we recommend that you use the carpet feet included with your scale. To do so, perform the following steps:

1. Remove the tab below each carpet foot.

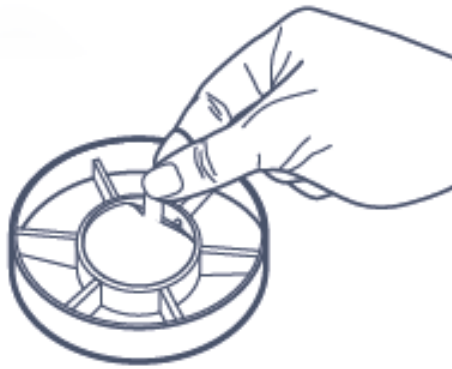

2. Stick each carpet foot on the Withings Body feet.

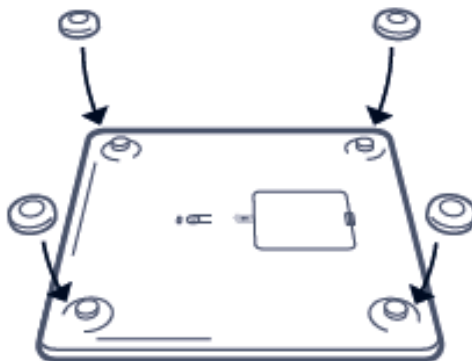

Updating your Withings Body

We regularly offer new firmware so that you can benefit from the latest features we add to our products. When new firmware is available, it is automatically installed without any prompt from the Health Mate app (only in Wi-Fi).

However, you can check if updates are available and force their installation whenever you want. To do so, perform the following steps:

1. Open the Health Mate app.
2. Go to **Devices**.

3. Tap **Withings Body**.

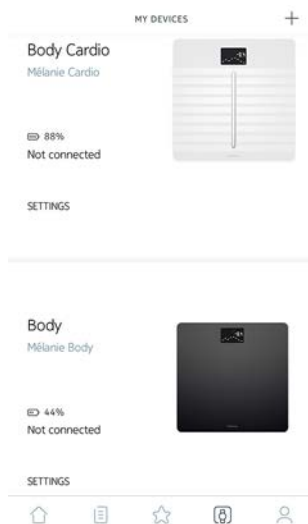

4. Tap **Check for updates**.



5. Press the button at the back of the scale and tap **Next**.

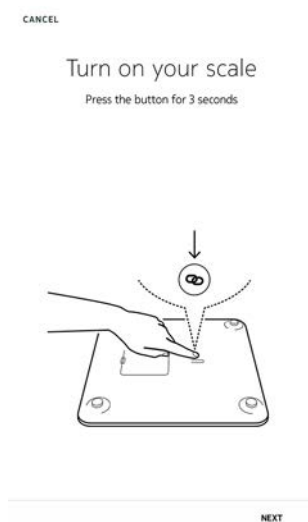

6. Tap **Upgrade**.

7. Tap **Close** when the upgrade is complete.

Note: You can check which firmware version your Withings Body uses in **Devices** > **Withings Body**.

Technology description

Weight

Your weight is measured thanks to four weight sensors placed below the surface of your Withings Body.

Body Mass Index

The Body Mass Index (BMI) is calculated based on your weight and height. It is an international standard adopted by the World Health Organization which helps evaluate the health risks linked to abnormal weight.

Generally speaking, a BMI between 18 and 25 is considered as “normal”, meaning that weight-related risks to your health are low. Please note, however, that BMI is only an indicator, and that it doesn't take into account a person's morphology.

User guide copyright

This User Guide is protected by Intellectual Property laws and copyright. Any reproduction, modification, representation, and/or publication without Withings prior approval is strictly prohibited. You may print this User Guide for your personal use exclusively.

For any questions, please contact Withings at: <https://support.withings.com/hc/en-us/requests/new>

Legal notice



By using your Withings Body you expressly agree to the Withings Services Terms and Conditions available on our [website](#).

Personal data

- Make sure you have read our privacy policy, which you can find on our [Privacy Policy](#).
- Make sure your Withings account password is secure enough to restrict access to your account. It should be at least eight-character long, have mixed case, and use a combination of alphanumeric and special characters.
- We recommend that you protect access to the Health Mate app with an additional passcode and/or Touch ID. You can do so from the app by going to **Settings** in the app and activating **Touch ID and Passcode**.
- We recommend that you export your data on a regular basis to local storage on your home computer. You can do so from the Health Mate [web interface](#) by clicking your **Profile picture** > **Settings** > **User Preference** > **Download my data**.

Safety instructions

Use and storage

- Use the product at temperatures between 5°C and 35°C (41°F and 95°F) with a relative humidity between 30% and 80%.
- Product may be stored in a clean location between -10°C and 50°C (14°F and 122°F) when it is not in use, with a relative humidity between 10% and 90%.
- This product is not a toy. Do not allow children to play with it.
- This device is designed for indoor use only.
- Do not allow the device to come in contact with liquids.

Location

- Do not use your Withings Body in a place that is too humid as it can affect the batteries.
- Make sure you use the carpet feet if you place your Withings Body on a carpet.

Service and maintenance

- Do not attempt to repair or modify your Withings Body yourself. Service and maintenance not described in this User Guide should be performed by professional technicians.
- If you have any issues, feel free to contact customer service at: <https://support.withings.com/hc/en-us/requests/new>.

Specifications

Withings Body

- Length: 325 mm (12.8") 300 mm (11.9")
- Width: 325 mm (12.8") 300 mm (11.9")
- Depth: 23 mm (0.90") 33 mm (1.3")
- Weight: 2.1 kg (4.6 lbs) 2 kg (4.4 lbs)
- Weight range: 5 kg - 180 kg (9 lbs - 396 lbs)
- Weight units: kg, lb, stlb
- Precision: 100 g (3.5 oz)

Display

- 6.1 cm x 4.1 cm (2.4" x 1.6")
- 128 x 64 pixels
- High-contrast lighting

Connectivity

- Wi-Fi 802.11 b/g/n (2.4 GHz only), compatible with WEP/WPA/WPA2 personal networks
- Bluetooth / Bluetooth Low Energy (Bluetooth Smart Ready)

Sensors

- 4 weight sensors
- Patented Body Position Detector via Position Control™ technology

Metrics

- Weight
- Body Mass Index (BMI)

Batteries

- Up to 2 years battery life
- 4 LR3 batteries

Features

- Automatic user recognition
- Weather forecast
- Baby mode
- Pregnancy mode

Compatible devices

- iPhone 4s (or higher)
- iPod Touch 5th Gen (or higher)

- iPad (2nd Gen or higher, as well as any iPad Mini)
- Bluetooth Low Energy compatible Android device

Compatible OS

- iOS 8.0 (or higher)
- Android 5.0 (or higher)

Document release overview

Release date		Modifications
June 2017	v1.0	First release
April 2018	v2.0	Privacy update
April 2019	v3.0	Withings version



The screenshots in this manual are used for explanatory purposes. Your actual screens may differ from the screenshots in this manual.

Warranty

Withings One (1) Year Limited Warranty - Withings Body

Withings warrants the Withings branded hardware product (“Withings Body”) against defects in materials and workmanship when used normally in accordance with Withings’ published guidelines for a period of ONE (1) YEAR from the date of original retail purchase by the end-user purchaser (“Warranty Period”). Withings’s published guidelines include but are not limited to information contained in technical specifications, safety instructions, or quick start guide. Withings does not warrant that the operation of the Withings Body will be uninterrupted or error-free. Withings is not responsible for damage arising from failure to follow instructions relating to the Withings Body’s use.

The warranty does not extend to:

- Any damage to the device resulting from abnormal or abusive use, negligence or lack of care, or accidental damage (such as dents).
- Indirect damages of any kind.

Regulatory statements

FCC ID: XNA-WBS06

This device complies with Part 15 of the FCC Rules. This equipment complies with FCC radiation exposure limits set forth for an uncontrolled environment. End users must follow the specific operating instructions for satisfying RF exposure compliance. This transmitter must not be co-located or operated in conjunction with any other antenna or transmitter.

Operation is subject to the following two conditions:

- (1) This device may not cause harmful interference, and
- (2) This device must accept any interference received, including interference that may cause undesired operation.

This device complies with the R&TTE Directive 1999/5/CE.

A copy of the EU Declaration of Conformity is available online at <https://www.withings.com/fr/en/compliance>